

# ROHS

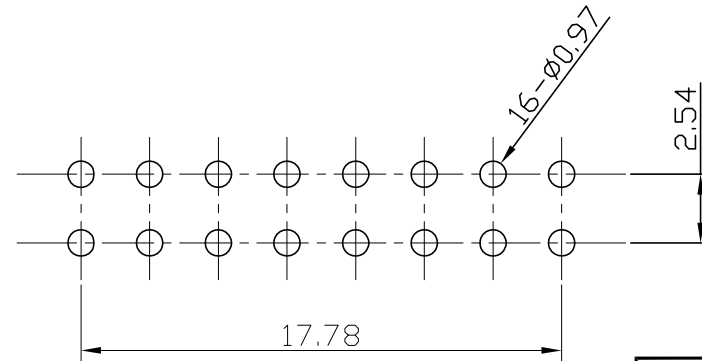

Model No.	COVER COLOR
DIP-821H-01	RED
DIP-821H-02	BLUE

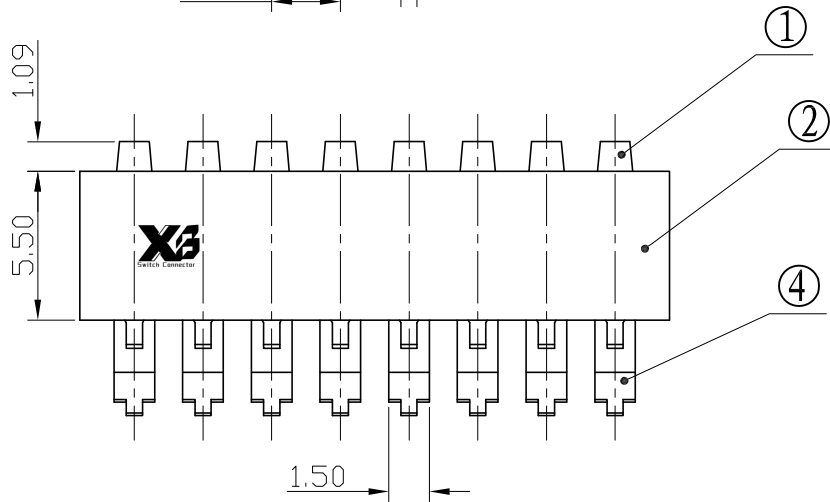
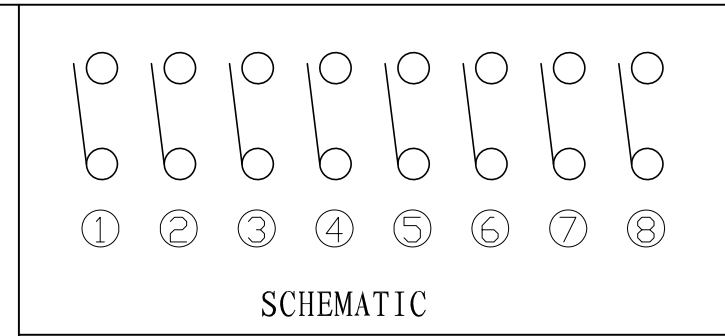
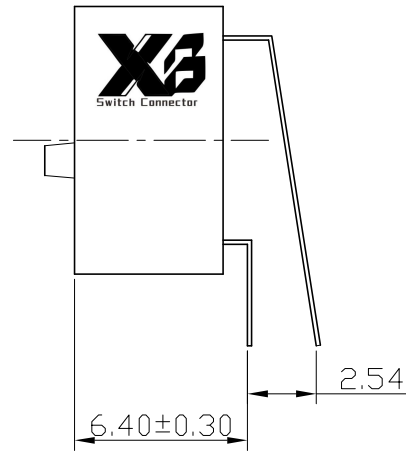
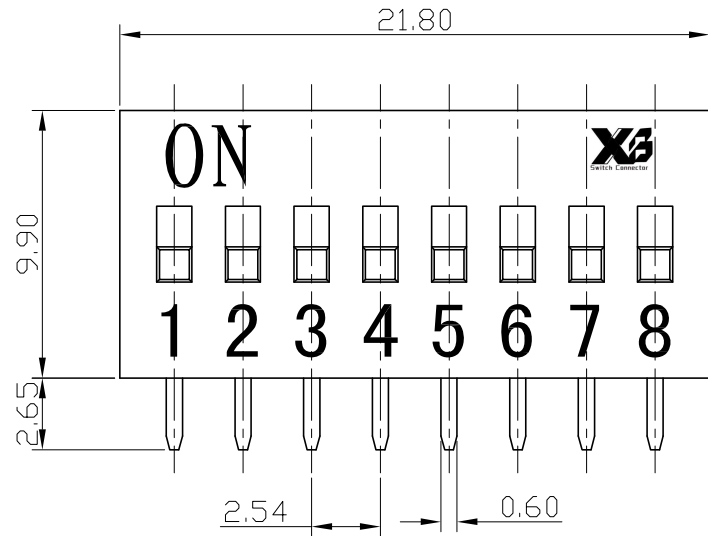

**东莞市溪榜电子有限公司**  
DONG GUAN XI BANG ELECTRONICS CO., LTD

TITLE : SLIDE DIP SWITCH

MODEL : DIP-821H (W01104)

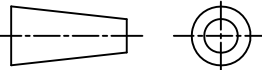

TOLERANCE  
 <=1.5mm ± 0.1  
 > 1.5mm ± 0.2  
 >=10.0mm ± 0.3

ANGLE TOL  
 ± 2°

UNIT	MM	DWN.	DATE
SCALE	3.5 : 1	CHK'D	DATE
VERSION	01	APPD.	DATE

NO.	PART NAME	MATERIAL	QTY.	FINISHING
4	TERMINAL	ALLOY COPPER	16	CUSN PLATING
3	BOARD	ENGINEERING PLASTICS	1	BLACK
2	COVER	ENGINEERING PLASTICS	1	RED / BLUE
1	KNOB	ENGINEERING PLASTICS	8	WHITE